

MYERS® MODEL CX 10 and 20 GPM High Pressure Reciprocating Pump

Strength and Versatility

The Myers CX Series combines manufacturing expertise and understanding of applications to provide a pump with strength and versatility for any demanding high pressure job. Contact your Pentair sales representative or customer service at 419-289-1144 for more details.

Wide performance range

- 7.4 – 10.4 gpm (28.0 – 39.4 lpm)
400 – 1500 psi (27.6 – 103.4 bar) (CX10)
- 15 – 20.8 gpm (56.8 – 78.7 lpm)
300 – 1000 psi (20.7 – 68.9 bar) (CX20)

Rugged design for continuous operation

- Solid cast iron power end.
- Constant lubrication of all working parts.
- High-strength cast iron, aluminum-bronze, Ni-Resist or stainless steel fluid end.

Whisper quiet operation

- Large oversized in-line suction and discharge valves allow complete filling of cylinder.
- Available with Ni-Resist cast fluid end for special applications where high heat transfer and corrosion resistance are required.



Product Specifications						
Temp. Rating °F (°C)	Sizes in inches (mm)					Approx. Weight lbs. (kg)
	Piston Stroke	Suction Size NPT	Discharge Size NPT	Input Shaft	Keyway	
180 (82)	1-1/4 (31.75)	1-1/2 (38.1)	1 (25.4)	1-1/8 (28.58)	1/4 x 1/8 (6.35 x 3.18)	104 (47)

Product Capabilities						
Catalog Number	Max. Rated Capacity GPM (LPM)	Max. Rated Pressure psi (bar)	Max. Rated Speed RPM	Cylinder Bore inches (mm)	Max. HP (kW)	Fluid End Material
CX10-15	10.4 (39.5)	1500 (103.4)	560	1-1/4 (31.75)	11.2 (8.4)	Cast iron or alum.-bronze
CX20-10	20.8 (79.0)	1000 (68.9)	560	1-3/4 (44.45)	14.4 (10.7)	Cast iron or alum.-bronze
CX20-10NR	20.8 (79.0)	1000 (68.9)	560	1-3/4 (44.45)	14.4 (10.7)	Austenitic gray iron Ni-Resist

* Pump performance data are based upon 100% volumetric efficiency and 85% overall efficiency.
** Ni-Resist fluid end for resistance to heat and corrosion.

Components

- Suction, Discharge** – Three suction ports, one discharge. Threaded for easy connections.
- Body** – High-strength cast iron, aluminum-bronze, Ni-Resist or stainless steel.
- Cylinder Liners** – Solid ceramic.
- Body** – Solid cast iron crankcase. Oil reservoir for complete component lubrication. Removable end plate for inspection.
- Crankshaft** – Ductile iron; ground, polished journals.
- Main Bearings** – Ball bearings (CX10) and roller bearings (CX20) offer minimum friction, longer service.
- Connecting Links** – Lightweight aluminum alloy; replaceable bronze bushings and babbitt sleeve bearings.
- Piston Assembly** – Molded Buna-N multi lip V-rings, backed by fabric-reinforced phenolic follower.
- Valve Assembly** – Corrosion-resistant springs and valves for long-lasting performance.

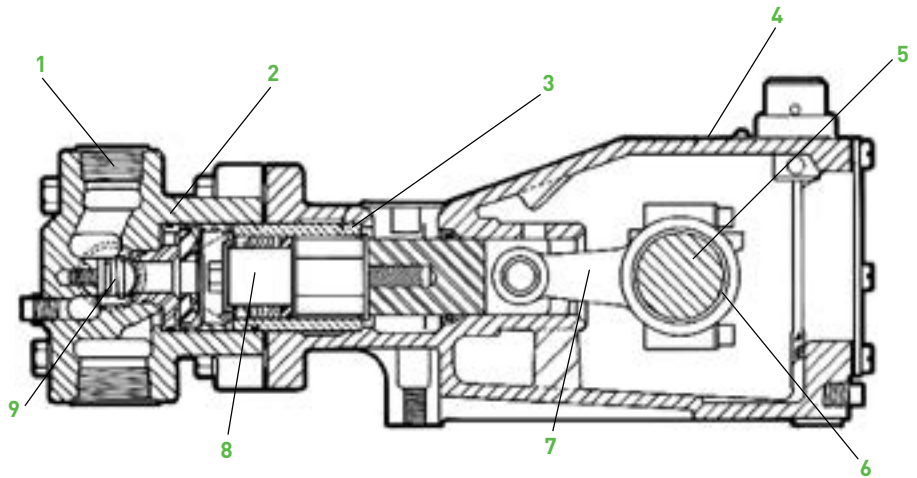

Dimensional Data

[Dimensions in mm]

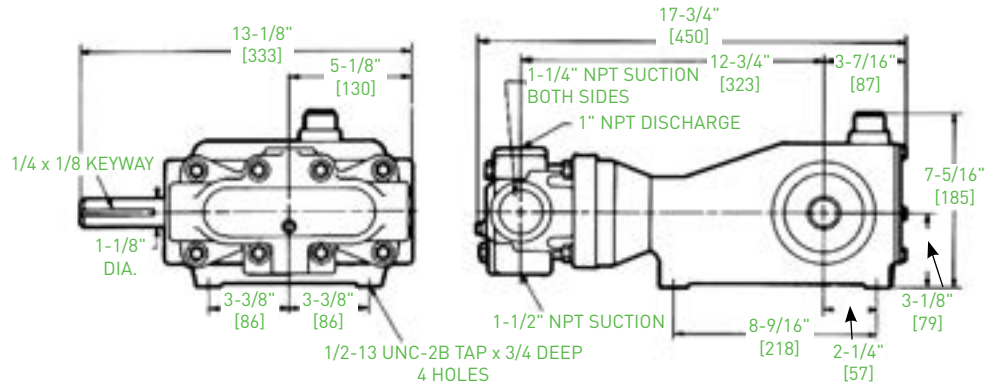

Performance Data							
Flow Capacity		Horsepower (Kilowatts) required for: psi (bar)					
CX10 GPM	RPM	400 (28)	600 (42)	800 (56)	1000 (70)	1300 (91)	1500 (105)
8.0	400	2.2	3.3	4.4	5.5	7.1	8.2
9.0	450	2.5	3.7	4.9	6.1	8.0	9.2
10.0	500	2.7	4.1	5.5	6.8	8.9	10.2
11.1	560	3.1	4.6	6.1	7.6	9.9	11.5
CX20 GPM	RPM	300 (21)	400 (28)	500 (34)	600 (41)	750 (52)	1000 (70)
15.6	400	3.2	4.3	5.4	6.4	8.0	10.7
17.6	450	3.6	4.8	6.0	7.2	9.0	12.0
19.5	500	4.0	5.4	6.7	8.0	10.0	13.4
21.8	560	4.5	6.0	7.5	9.0	11.2	15.0

Power based on 85% mechanical efficiency.
Displacement based on 100% volumetric efficiency.



740 EAST 9TH STREET,
ASHLAND, OHIO 44805
WWW.FEMYERS.COM

490 PINEBUSH ROAD, UNIT 4,
CAMBRIDGE, ONTARIO N1T 0A5
WWW.FEMYERS.COM

Because we are continuously improving our products and services, Pentair reserves the right to change specifications without prior notice.
K3236 01/03/14 © 2014 Pentair. All Rights Reserved.